

# Rho 1000 Series

## The most productive UV flatbed printers



The Rho 1000 Series is the flagship of Durst's comprehensive range of flatbed and roll to roll UV inkjet printers. The 1000 Series offers a unique combination of fine quality print with the highest print speed in the market whilst providing unrivalled versatility not available with other high end machines. There are different levels of automation up to full automation designed to best suit the requirements of the customer.

### **Rho 1012**

The Rho 1012 is the most productive 12 picolitre flatbed printer in its class. With a very small ink drop size of only 12 picolitres, it is capable of printing with unrivalled quality at 1000 DPI at a speed of up to 490 m<sup>2</sup> per hour. Furthermore, the Rho 1012 offers an unique level of media flexibility.

### **Rho 1030**

The Rho 1030 will print up to 1000 m<sup>2</sup> per hour without compromising the quality of print. It is fully automated with auto loading and unloading tables whilst it is ideally suited to incorporation into an industrial production line.

The Rho 1000 Series of printers all come with the option of different levels of automation. The Rho 1012 is ideal for three quarters automation, which includes manual loading supported by auto registration with 2 pin front stops and auto unloading onto a stacker. The Rho 1030 can take advantage of full automation with media loaded onto an auto feeder and passes over a registration table with two pin front stops, and transport through the printer onto a stacker ready for dispatch. In addition, there are both a roll to roll option and a roll to sheet option available for the Rho 1012 and Rho 1030. Each machine can be configured in a format most suited to a customer's requirements.

## Durst. The industrial inkjet specialist



Since 1936 Durst has been responsible for pioneering better and faster methods of large format image reproduction. The company started with analogue photo technology and later moved into digital photo laser imaging. It was one of the first to develop large format inkjet printing, initially for the graphic arts market and, most recently, it successfully extended the technology to different industrial inkjet applications. Today, we see ourselves as an industrial inkjet specialist. Our new research building in Lienz, Austria, is evidence of our commitment to both the science of inkjet printing and our pursuit of new applications for inkjet printing.

Our machines have the ability to change existing markets and provide our customers with new business opportunities. We also make it our duty to ensure sustainable development, providing machines that are kinder to the environment and use much less ink and energy.

We are concerned with minimising storage and wastage by providing the ability to print on demand across many different applications and industries.

By optimising the performance of our printers through both physical and chemical sciences, we succeed in providing our customers with a competitive and profitable edge. That is why we believe that Durst is: "The industrial inkjet specialist."

## Durst Technology

The materials used in manufacture of all Durst large format inkjet printers are of the highest quality which results in consistent high performance and the most reliable machines in the market. This ensures 24/7 production and minimum downtime.

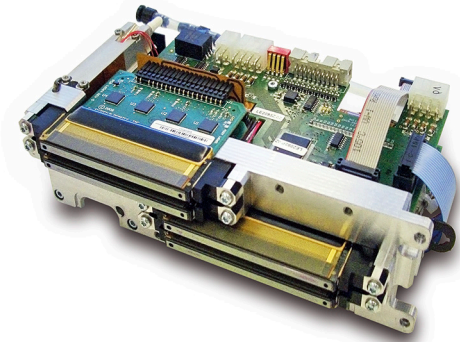

### Durst Quadro Array printhead technology

The Rho 1000 Series of printers have the latest Durst Quadro Array 12M printheads for the Rho 1012 and 30M printheads for the Rho 1030, which have 1024 nozzles per array. There are over 65,000 inkjet nozzles in the print carriage, for high productivity and uncompromised quality. The temperature of the ink is precisely controlled via the ink feeding system. The drop straightness, with a deviation of only 1.5 $\mu$ , provides an even higher image quality. This provides pin sharp text as small as 4 pt. and banding-free full colour images, without "smoothing" caused by overlapping the printing of ink drops. The nozzle plate is now constructed of silicon oxide and MEMS production technology and anisotropic etching for greater robustness and accuracy.

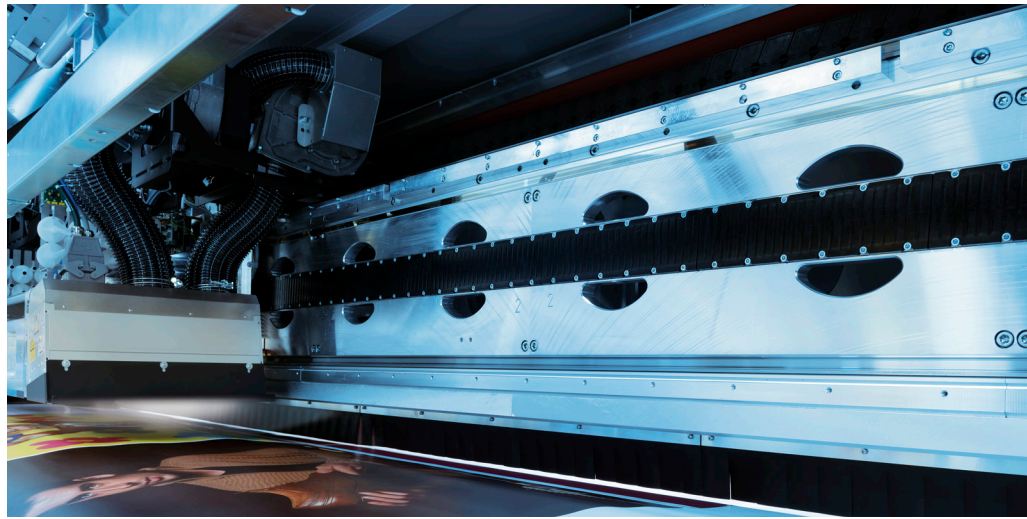

### Durst Rho Inks

Durst Rho inks offer perfect adhesion to the widest range of media. Their high level of pigmentation provides excellent coverage and cost efficiency as a result of requiring less ink per square metre. All Rho UV inks are free of VOCs and low odour. Durst Rho inks have been awarded the prestigious GREENGUARD Certification.

### Magnetic linear drive

The carriage transport is by advanced magnetic linear drive. This further ensures consistently accurate printing. Precision built by Durst for greater accuracy and reliability, the shaft on which the printhead travels is accurate to within 2 $\mu$  tolerance.

# Rho 1012

## The most productive 12 picolitre flatbed printer in its class

The Rho 1012 sets the quality standard for high end industrial inkjet productivity. This is due to Durst's latest Quadro Array printhead technology which features very small droplets of only 12 picolitres and with over 65,000 nozzles in the print carriage. This enables a very high printing speed without compromising the quality. Now there is a system that matches offset for quality at a new level of productivity whilst offering the flexibility of digital inkjet printing. From short runs, even one offs, to high volume production, the Rho 1012 provides the economical solution.

### Advantages of the Rho 1012

- Latest Durst Quadro Array 12M printhead technology for outstanding print quality and the highest printing speed
- Continuous printing process maximises productivity
- Left and right registration enables parallel printing of boards side by side
- Mechanical 2 point pin registration enables perfect front and reverse side printing
- Ink options include the addition of light colours, process colour addition (PCA), orange and green or orange and violet
- Upgradable to different configurations
- Highest reliability in the market (24/7 production)



### Registration table

The board is loaded directly onto the table. Mechanical 2 point pin registration ensures exact media registration in xy direction. Pulleys move the board to the left or right so that it is flush with the edge. The precise registration of the media enables parallel printing of multiple boards.

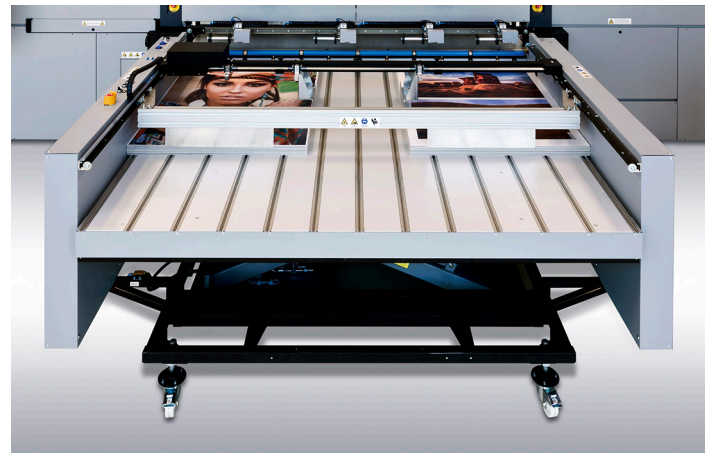

### Durst stacker

The stacker will also handle two parallel stacks at the same time. There is an integrated alignment feature for the stacks (x and y direction) and the sheets can be loaded directly onto pallets.

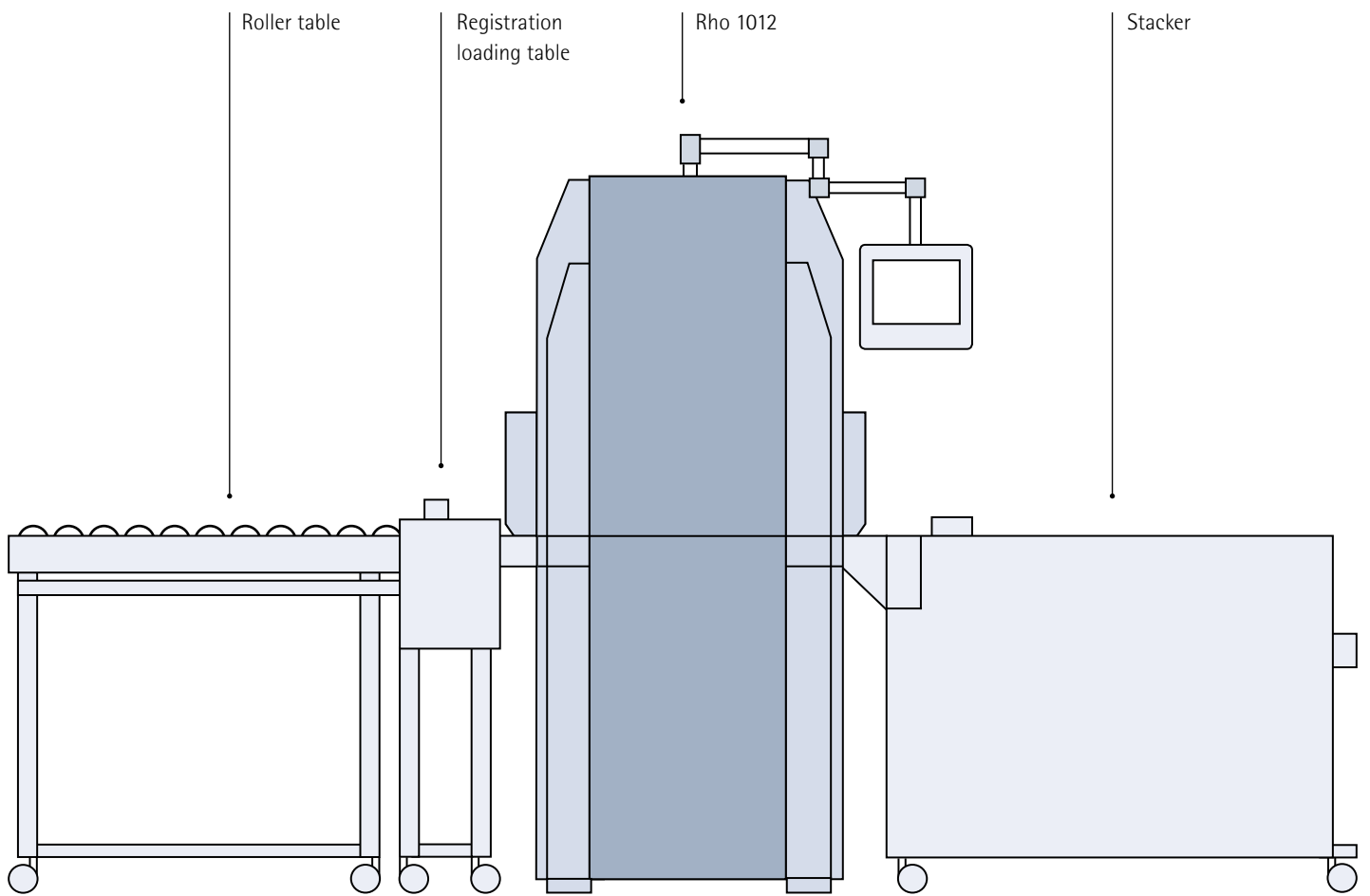

#### Roll to roll printing

The Rho 1012 allows for a fast change from rigid to roll media. Heavy rolls are loaded onto the roll media device and dancer rolls ensure precise tensioning of the media. The roll can be re-adjusted during printing and the printed roll is precision wound.



#### Roll to sheet

There is a special option of a fully automated roll to sheet system which uses the roll media device at the front. The roll media instead of passing through the printer and being wound on to another roll is fed to the XY cutter and the cut media is in parallel stacked on the Durst stacker ready for dispatch.

#### Optimal system configuration

The Rho 1012 printer allows for different system configurations in order that customers can tailor the printing system so that it best suits their requirements and maximises their workflow.

#### System integration

The Rho 1012 can be integrated into an industrial production line. The benefits include maximising productivity whilst providing the ability for "just in time" production which reduces storage costs for printed products and the overall delivery time can be significantly shortened.

# Rho 1030

## The fastest fully automated UV flatbed printer

The Rho 1030 is the fastest flatbed in the market. It is ideal for fully automated production whilst offering the ability to provide short runs, variable data printing and very fast media change. Uniquely it maintains Durst's fine level of quality with pin sharp detail and text and smooth solid colours without reducing productivity.

### Advantages of the Rho 1030

- Latest Durst Quadro Array 30M printhead technology with over 65,000 nozzles in the print carriage for outstanding productivity without compromising quality
- Full automation of boards from loading on a pallet to delivery on the automated stacked ready for dispatch
- Ink options include Process Colour Addition (PCA) for extended colour gamut, addition of light colours
- Ideal for incorporation into an industrial production line
- Left and right registration enables parallel printing of boards
- 2 point pin registration for front and reverse side printing
- Highest reliability in the market (24/7 production)

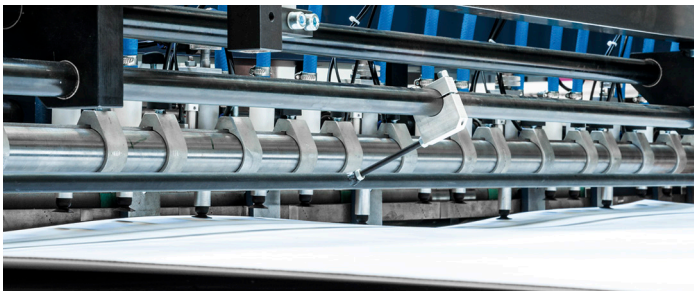

### Mirus feeder

The latest advance in automated handling of sheets is the Mirus feeder and stacker. The feeder allows for loading of stacks up to a weight of 1500 kg on pallets from the sides and two parallel stacks can be loaded at the same time (left and right registration). The feeder is capable of handling media up to 5 mm thickness and a bend of up to 20 mm.



### Registration table

The board is loaded directly onto the table. Mechanical 2 point pin registration ensures exact media registration in xy direction. Pulleys move the board to the left or right so that it is flush with the edge. The precise registration of the media enables parallel printing of multiple boards.

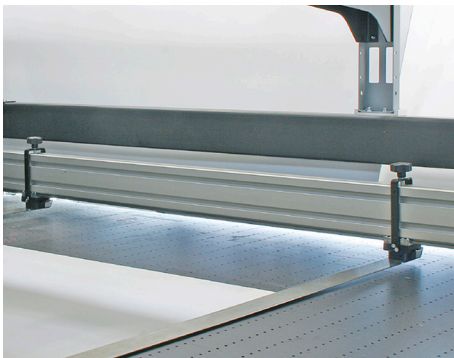
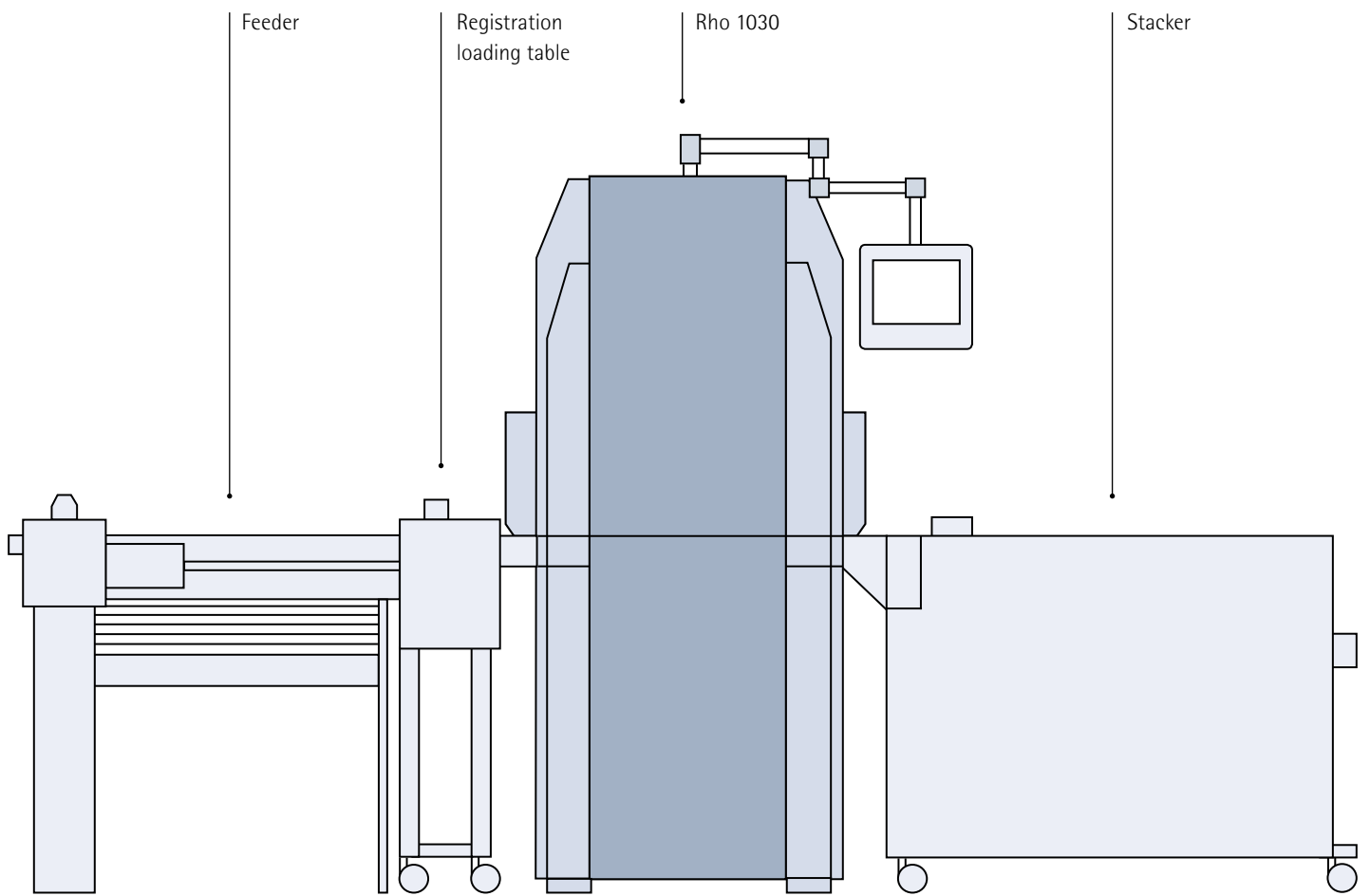

**Corrugated board printing option**

This option allows for the direct printing of corrugated board. It has adjustable media support guidances and is designed for handling B, E, and F flutes. The maximum bent of corrugated media is 20 mm.



**Mirus stacker**

The stacker will also handle two parallel stacks at the same time. There is an integrated alignment feature for the stacks (x and y direction) and the sheets can be loaded directly onto pallets.

**Rho 1030 system integration**

Different system configurations are available with full automation taking advantage of the Rho 1030's exceptional high printing speed.

The Rho 1030 can be integrated into an industrial production line. The continuous media transport system will control the passage of the media through the entire process from the loading of board, through the printing, top coating (if required) to stacking the finished items ready for dispatch.

The automated production line maximises productivity whilst providing the ability for "just in time" production. This reduces storage costs for printed products and the overall delivery time can be significantly shortened. Many different designs are possible without increased costs even for one-offs.

# Rho 1000 Series workflow features

## Variable Data Printing (VDP) and job workflow optimisation

Durst leads the way with the optimisation of job workflow. The Rho 1000 supports the new PDF/VT file format, offering the combination of high level graphic design features with VPD. Adoption of the ISO 16612-2 standard for the Caldera RIP enables the processing of optimised multipage PDF files and the output is multiple ripped files which are then transferred to the spooler of the Rho. This also enables parallel printing, if required.

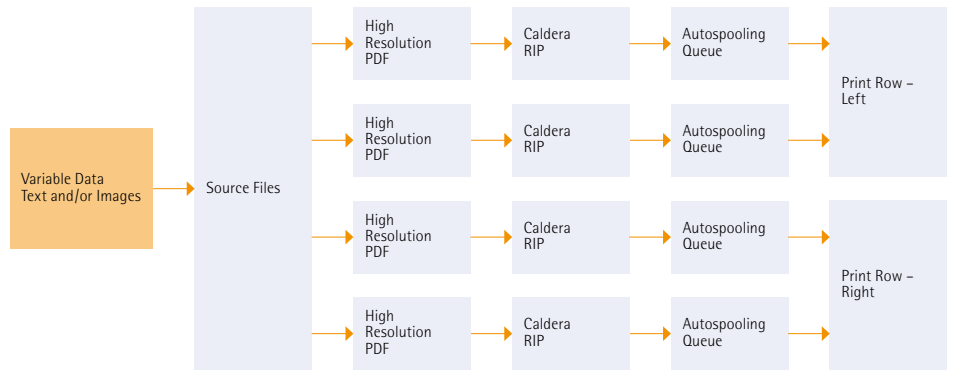

## Print to kit

The Rho 1000 Series, with its unique flexibility and productivity is the ideal solution for Print to Kit, which goes even further than variable data printing for the automatic handling of data changes during the printing process. It includes changes of the type of media, even from rigid to roll, and its size and thickness without detriment to productivity. It means that a print run of just one is practical, therefore finishing a complex job for one customer on the same machine is both effective and cost efficient. The overall benefit is that the Rho 1000 is capable of high volume, profitable printing 24/7 whilst printing different sizes and media and changing from roll to roll to flatbed operation. As previously described, the Rho 1000 is designed to integrate into a continuous production system and will thus provide a complete high production large format printing plant that is capable of handling complex print orders in one operation.

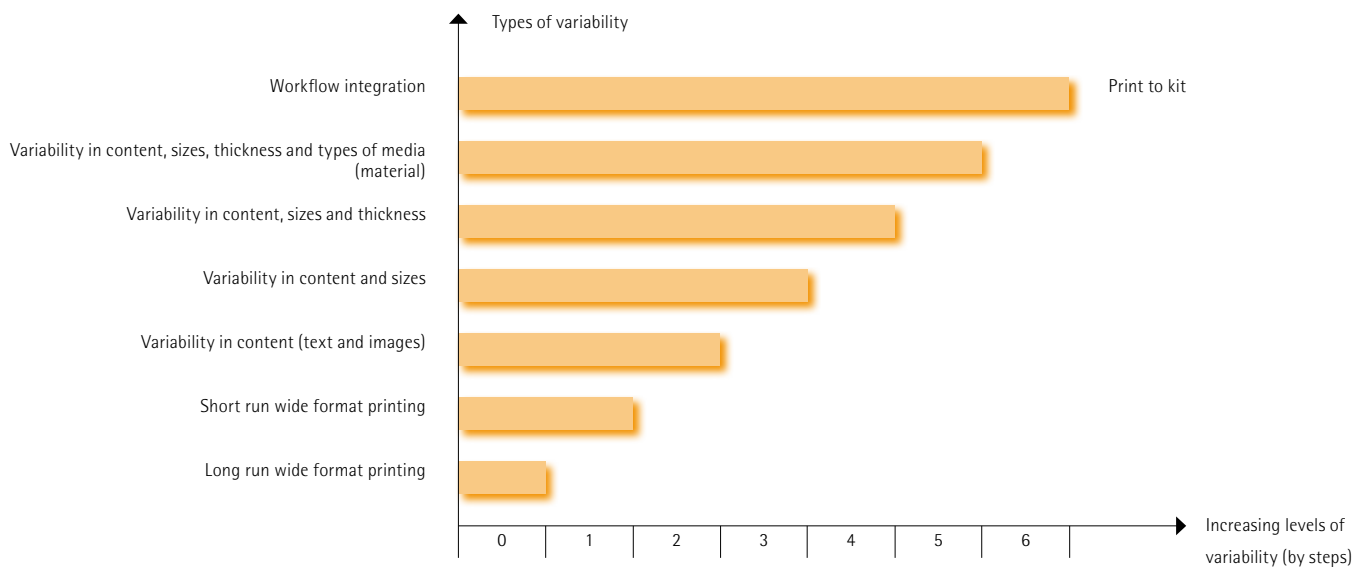



# Rho 1000 Series ink options

## Rho POP Ink

The Rho POP Ink is an economical solution which ideal for POP applications. It is optimised for PVC, styrene, polyester and various paper surfaces. It offers high surface hardness, gloss finish, low odour and 2-3 years' outdoor lightfastness.

## Rho Paper and Board Ink

This ink system is specifically designed as an economical solution for paper and corrugated board applications. The ink has the highest performance on coated papers as well as on highly absorbent papers such as Kraft and Test liner. It is fast curing to prevent ink migration into the substrate. Also, there is no set off at stacking or manual handling.

All Rho 1000 inks are environmentally friendly, they contain no harmful VOCs, they are odourless and non toxic.

## Rho ink colour options

Different ink options are offered on the Rho 1000 Series these include:

- Special light colours (Lm and Lc) for even finer colour graduations and perfect skin tones
- Process Colour Addition (PCA). Either orange and green or orange and violet, extend the colour gamut and provide perfect rendition of even difficult corporate colours

## Environmental features of Durst Rho inks Recyclability

The UV curing inks dry by exposure to UV light and this reduces the drying energy needed compared to having thermal driers, which is of environmental benefit.

Additionally compared to solvent based inks and even many water based inks which also contain organic solvents, high quality UV curing inks, such as the Rho 1000 inks, liberate no VOC's during the drying process.

The recyclability of the printed board is an important aspect in today's environmental awareness and UV curing printed output maintains a high level of recyclability, since, during the pulping process, the ink, which effectively forms a surface "plastic" layer, is easily separated from the fibres and then removed. This is in contrast to some water based dye-ink systems which permanently stain the fibres and degrade the recycled fibre quality.

## Health and safety

Questions are sometimes raised about the health and safety aspects of UV curing inks but, in practice, they are easily handled with routine industrial hygiene practices and once printed and cured present no health and safety issues. Historically, some UV curing inks have had a characteristic odour, but with the new generation of products this is very low and, in the case of the Rho inks, they have no residual odour, which further benefits the user by broadening the applications they can access. Furthermore, Durst Rho inks are entirely free of VOC's.

There are some specific applications where caution is needed about the use of UV curing inks. For instance they would not be recommended for any application where direct food contact is anticipated. This is because migration of trace quantities of the ink may take place. Whilst this is so low that it represents no hazard (a few parts in a billion), it nevertheless is not recommended.

Additional process colours extend the colour gamut.

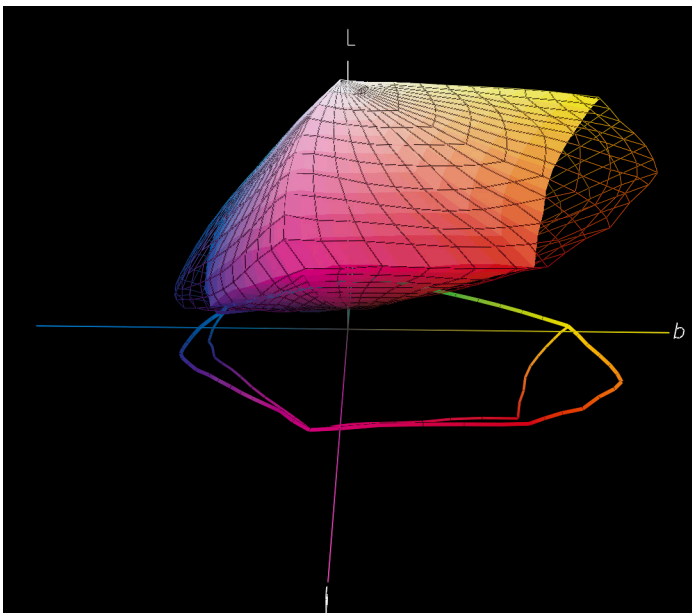

Orange and violet

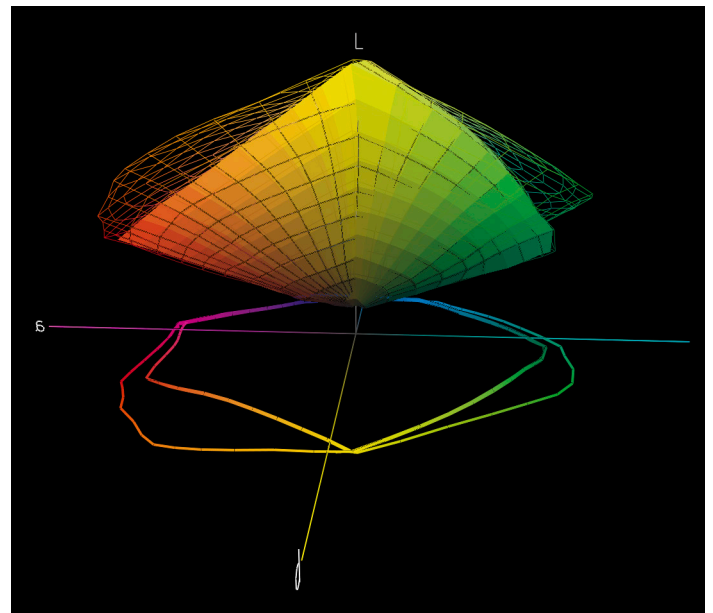

Orange and green

## Using the Rho 1000 Series

Companies using a Rho 1000 have already come to appreciate many unique benefits. Now, with the Rho 1012 they can also enjoy a quality not previously available with other high end machines.



Users of the Rho 1000 have come to appreciate the flexibility and productivity of the machine and the following information has been supplied by their practical experiences with particular reference to variable data printing (VDP) and printing to kit. However the arguments for using VDP and printing to kit also strongly apply to high volume industrial wide format production printing. This is borne out by the fact that the average run length per job printed with UV inkjet has increased dramatically over the last ten years.

Durst customers have made their own comparisons between analogue printing processes and the Rho 1000. They have found that the Rho 1000, in many instances, proved to be not only faster in production, but also better in terms of cost, i.e. press preparation. Furthermore, the Rho also provided the advantage of allowing variable data printing and even printing to kit whilst still maintaining its high level of productivity.

### **Variable Data Printing. Combining digital print with analogue printing.**

A typical example of using the Rho's variable data printing ability was by a Durst Rho 1000 user for an automotive customer in France which required several thousand outdoor displays. The customer wanted to change the number plate on the car according to the department and/or city where the display would be located. The image of the car and background was printed using screen print and the 'variable' data was added in a second shift on the Durst Rho 1000. With the Rho 1000's automated printing line, incorporating its media feeder and stacker, it could be integrated to interface with an existing screen printing production line.

### **Print to kit**

A German print production house believes that the Rho 1000 is the only machine on the market that can truly print a whole mixed job in individual units successfully and cost efficiently. This can represent a major advantage when required to respond very rapidly to supplying advertising kits to individual branches of a large retail chain.

Different data, sizes, thicknesses and media can all be handled in one production process and with the Rho 1000.



**Print on demand and late stage customisation**

A family run packaging company now in its third generation has worked in the carton and corrugated packaging industry since the outset. It believes that the Rho provides the answer to the ever increasing demands placed on it in terms of delivery and volume.

The company CEO said: "We no longer have to carry a large stock of printed material waiting for finishing and dispatch to various retail outlets, for example. We can respond even faster by printing the complete job direct onto the corrugated boards, successfully eliminating the lamination process and after that the boards are finished digitally using our automated cutter. This not only eliminates holding large volumes of printed stock, but also allows for customisation of the individual items."

**Unattended printing and high environmental standards**

A Japanese company founded about 30 years ago and since then has used flexo printing and die cutting technology to produce corrugated packaging. A major area of the business is in providing large format transport packaging. Much of the time the Rho is left to work unattended. This allows the operator time to also control the digital finishing. Furthermore, many of the company's customers have adopted strict environmental standards for their suppliers. For that reason it was essential that the Durst Paper and Board Ink is completely free from traces of heavy metals or VOCs.



**Fast turnaround**

Another German company, which has been in the carton and corrugated packaging market for six decades, believes that the high quality digital print and productivity of the Rho allows them to react much faster and with more flexibility. A company spokesman said: "Today, displays need to be produced much faster, prototypes and short runs need to have the same quality and appearance as offset printed long runs. 5 prototypes today, tomorrow 200 displays in different language versions, would have hardly been possible with traditional printing and converting technology. We believe that this is the way forward for a successful future".



# Technical Data

## General specifications

### Dimensions:

Width: 716 cm (282 in.)

Length with roll tables: 510 cm (201 in.)

Length without roll tables: 230 cm (91 in.)

Height: 258 cm (102 in.)

### Weight:

Approx. 7.500 kg (16.600 lb)

### Safety standards:

Complies with currently valid guidelines



### Printing system:

Patented Durst flatbed system with Quadro® array technology for the finest quality and the highest speed.

### Resolution:

- Rho 1012: 1000 dpi
- Rho 1030: 600 dpi

### Colours:

Standard: CMYK

Optional: Light Cyan and Light Magenta, Process Colour Addition (PCA) either orange and green or orange and violet.

### Inks:

UV-curable pigment inks for interior and exterior applications.

### Ink supply:

Integrated ink tanks with 10 litre capacity per ink, refillable during the printing process.

The refill inks are in 5 litre, non-returnable containers, easily disposed in collapsed condition, thus avoiding pollution to the machine and the environment.

### Software/RIP:

Durst Rho Linux software for very fast processing with minimum storage capacity on the hard disk.  
External Caldera RIP Server (GrandRip+)

### Productivity

#### (on full width at continuous production):

- Rho 1012 up to 490 m<sup>2</sup>/hour (5.300 sq. ft./hour)
- Rho 1030 up to 1000 m<sup>2</sup>/hour (10.700 sq.ft./hour)

## Media specifications

### Media types:

Wide range of uncoated and coated materials – also textured surfaces such as hard foam sheets, soft foam sheets, aluminium, acrylic glass, polycarbonate sheets etc.

### Maximum printing width:

250 cm (8 ft.)

### Maximum printing length:

Only restricted by media length

### Maximum thickness:

Standard: 40 mm (1.58 in.)

Industrial Version: 70 mm (2,75 in.)

### Maximum media weight on belt:

Standard: up to 50 kg (110 lb)

Industrial Version: up to 120 kg (265 lb)

### Smallest sheet size:

DIN-A3 – 29.7 × 42 cm (12 × 17 in.)

### Registration of materials:

Materials are registered at the leading edge by means of fibre optic sensors or alternatively by mechanical front stops.

An encoder measures the transport sequences, ensuring utmost precision in image alignment.

### Location requirements

#### Space requirement:

Min. 10 × 8 m (33 × 26 ft.)

#### Maximum height:

2.400 m (8.000 ft) above sea level

#### Temperature range:

+15 °C to +30 °C (+59°F to 86°F) non-condensing

#### Relative air humidity:

25 – 80 % non-condensing

The Durst logo, consisting of a stylized 'durst' in a blue, lowercase sans-serif font, preceded by a small graphic of three colored squares (blue, orange, green).

**Durst Phototechnik  
AG  
Large Format Printing**

Julius-Durst-Strasse 4  
39042 Brixen/Bressanone, Italy  
P.: +39 0472 81 01 11  
F.: +39 0472 83 09 80  
www.durst-online.com  
info@durst.it

**Durst Phototechnik  
Digital Technology  
GmbH**

Julius-Durst-Strasse 11  
9900 Lienz, Austria  
P.: +43 4852 7 17 77  
F.: +43 4852 7 17 77 50  
www.durst-online.com  
info@durst-online.at

The latest technical developments are constantly being incorporated into Durst products. Illustrations and descriptions are therefore subject to modification. All rights reserved on images and illustrations.

Durst® is a Registered Trade Mark

Copyright Durst Phototechnik AG, 03/2013  
IX20925

